

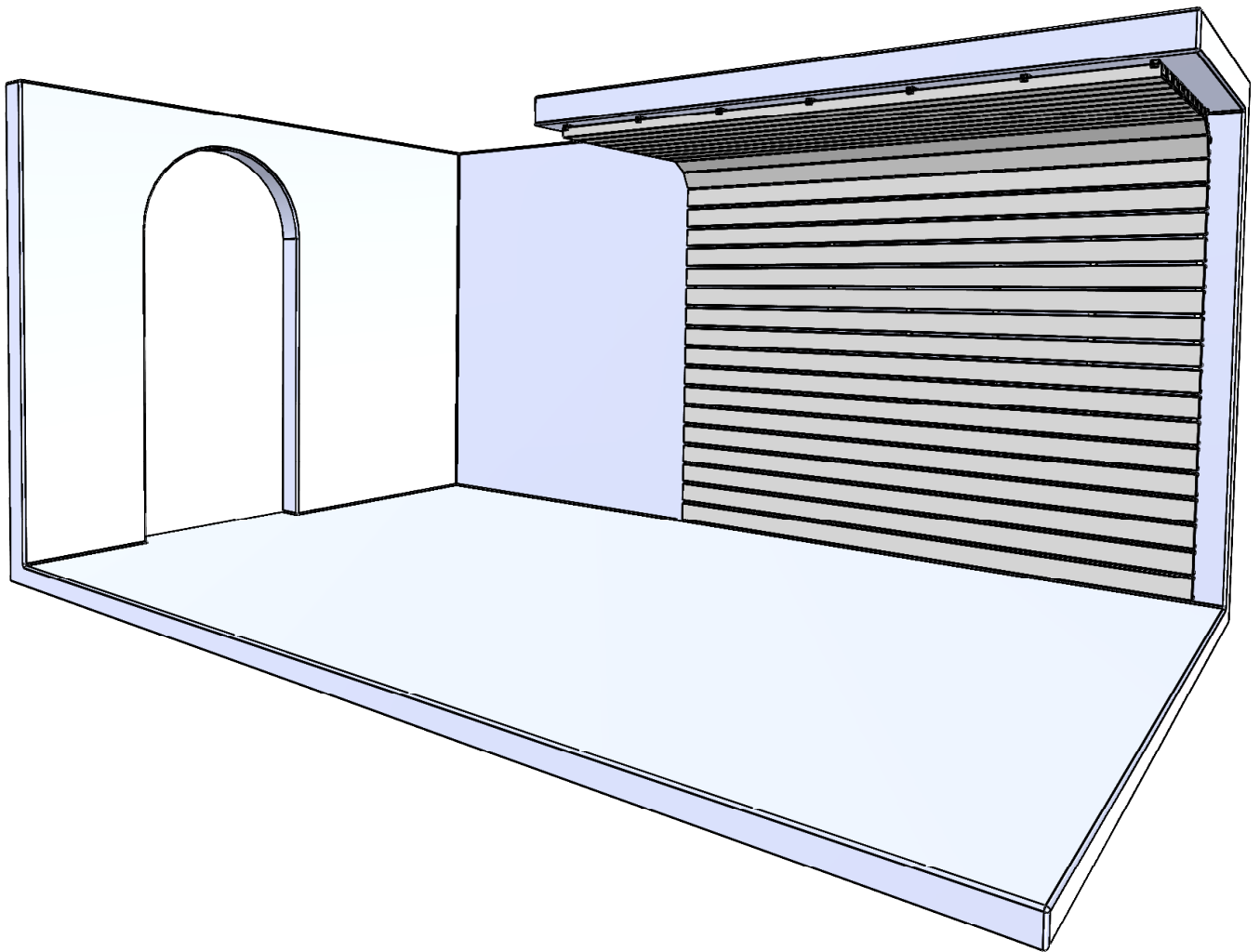

ZINTRA STICKS

TYPICAL LANDSCAPE TRANSITION ASSEMBLY INSTALLATION INSTRUCTIONS



PARTS AND HARDWARE

FOR A TYPICAL ASSEMBLY

ZINTRA STICKS - (28) WIDE OR (55) NARROW

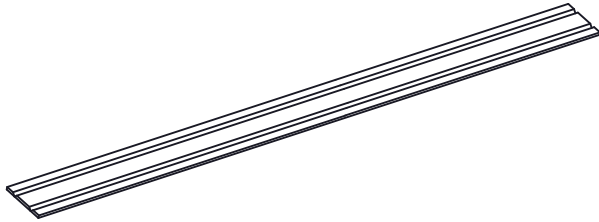

(2) STANDARD ALUMINIUM TUBE WITHOUT NOTCHES

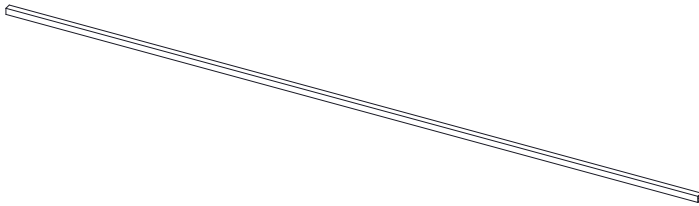

(21) STANDARD ALUMINIUM TUBE WITH NOTCHES

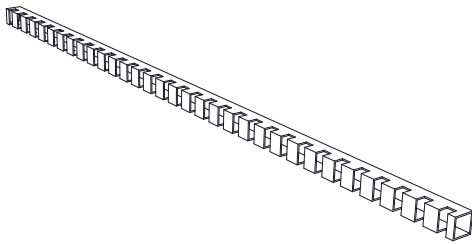

(14) NYLON UNTHREADED SPACERS

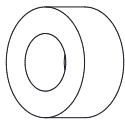

(7) CORNER ZINTRA SUPPORT

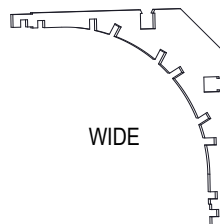
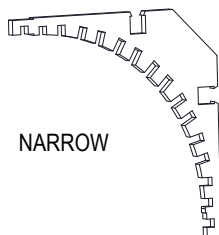

YOU WILL NEED

(42) SUITABLE SCREWS

SCREWS ARE NOT INCLUDED - INSTALLER TO SUPPLY BASED ON FIXING SUBSTRATE

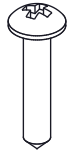

SPIRIT LEVEL

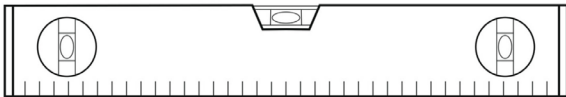

DROP SAW WITH SUITABLE BLADE FOR ALUMINIUM CUTTING

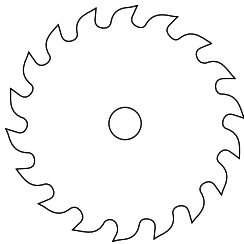

DRILL

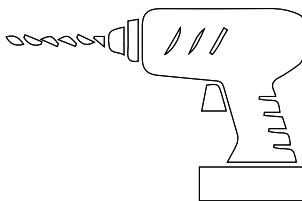

TAPE MEASURE

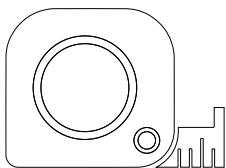

STEP 1

MEASURE THE HEIGHT [X] OF THE INSTALL AND CUT THE ALUMINIUM TO SUIT

NOTE: AFTER MEASURING AND MARKING WHERE TO CUT THE ALUMINIUM TUBE, COUNT THE NUMBER OF NOTCHES TO ENSURE IT WILL SUIT THE QUANTITY OF STICKS REQUIRED. FOR EXAMPLE, A WIDE STICK USES 4 NOTCHES, THEREFORE THE NOTCHES IN THE ALUMINIUM TUBE WILL NEED TO EQUAL A MULTIPLE OF 4.

USE A LASER LEVEL OR SPIRIT LEVEL TO MARK ALUMINIUM POSITION ON THE WALL.

MAX DISTANCE FROM TUBE CENTRES IS 450mm [17.71"]

MAX DISTANCE BETWEEN END OF STICK AND FIRST TUBE CENTRE IS 150mm [5.9"]

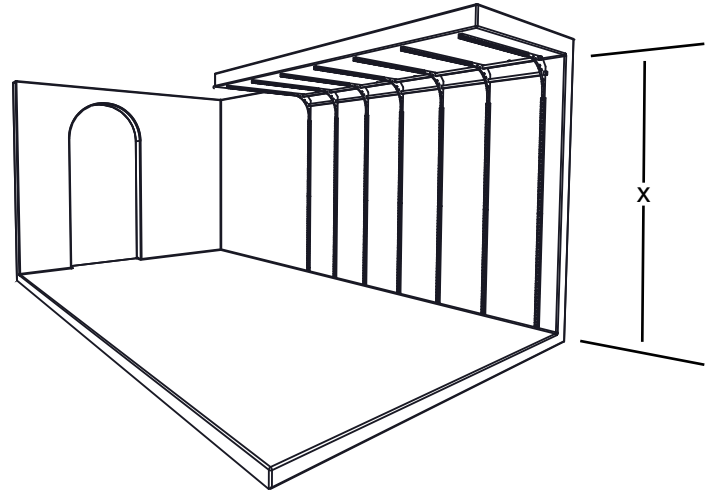

STEP 2

CONTINUE MARKING TUBE LOCATIONS ALONG THE INSIDE OF THE WALL AT A MAXIMUM OF 127mm [5"] CENTRE SPACING. THE TUBE CENTRE WILL ALSO ACT AS THE LOCATION FOR THE NYLON UNTHREADED SPACERS TO BE SCREWED IN.

MAX DISTANCE FROM TUBE CENTRES TO END OF ALUMINIUM NOTCHED TUBE IS 199mm [7.8"]

NYLON UNTHREADED SPACERS

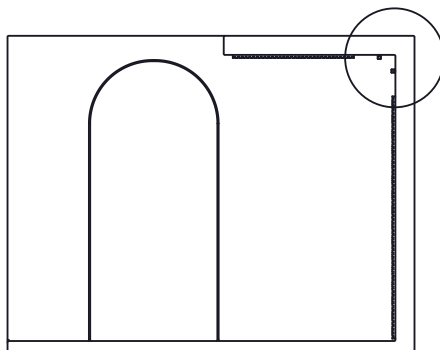
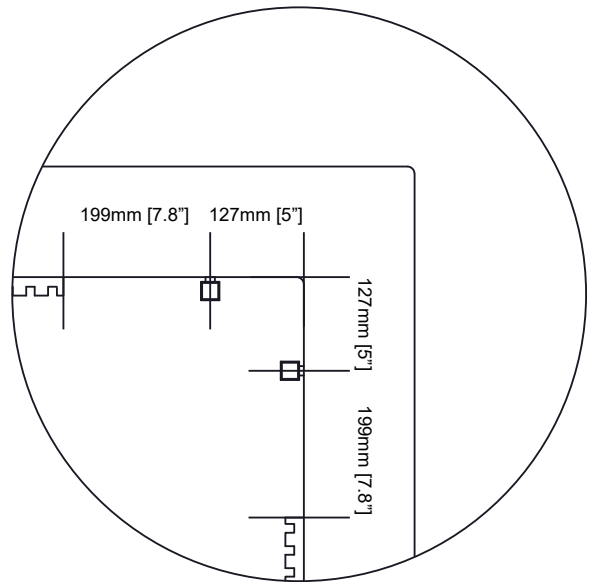

STEP 3

DRILL HOLES IN ALUMINIUM TUBES IN LOCATIONS TO SUIT SUPPORT IN WALL (STUD LOCATION ETC)

SCREW ALUMINIUM TUBES TO WALL

DRYWALL SURFACE: USE DRYWALL ANCHOR AND SUITABLE SCREW

TIMBER SURFACE: USE SELF TAPPING TIMBER SCREW

MASONRY SURFACE: USE MASONRY ANCHOR AND SUITABLE SCREW

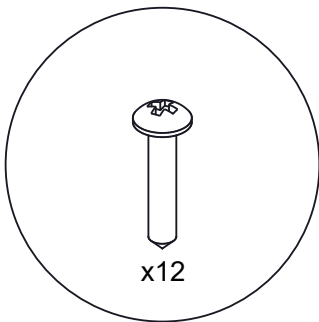
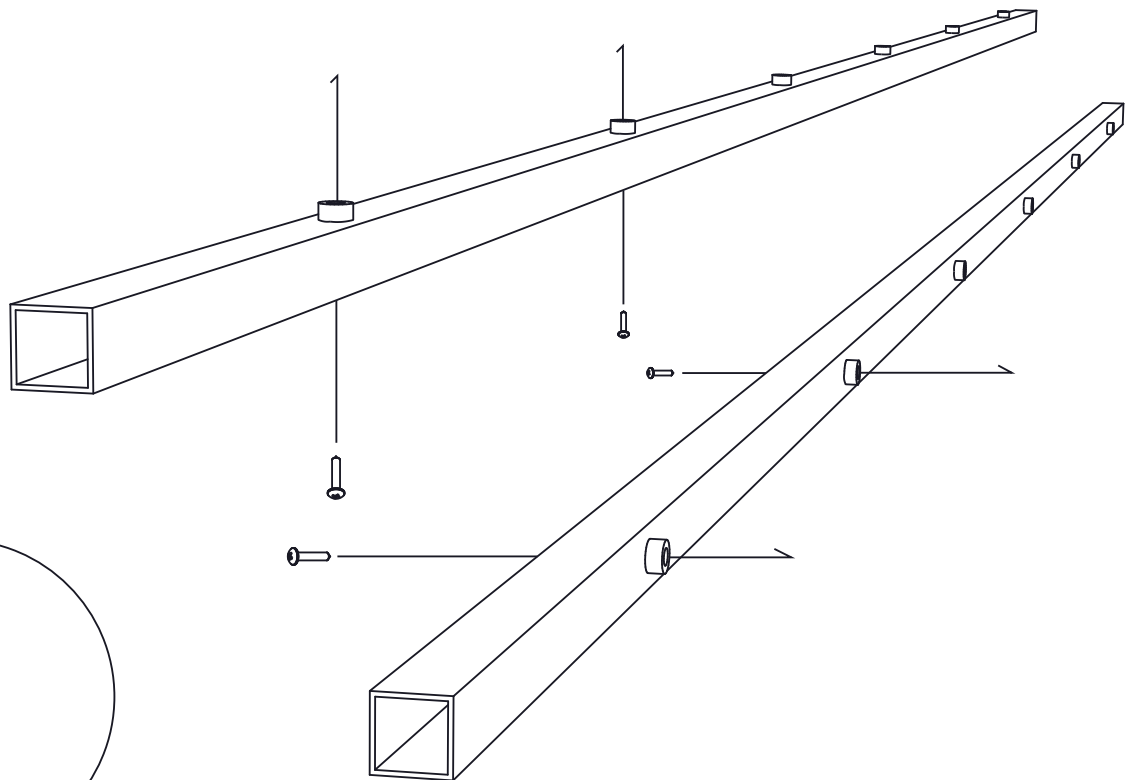
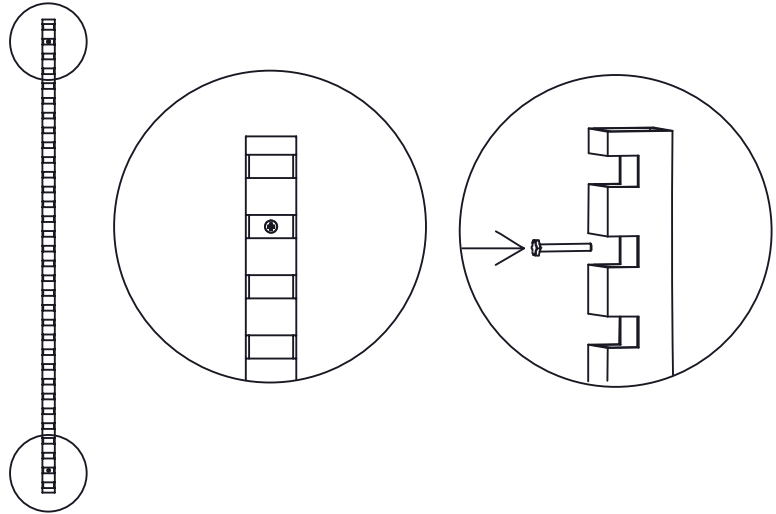

STEP 4

PUSH CORNER SUPPORT PIECES ONTO TUBES.

NOTE: THESE NEED TO BE LOCATED TO LINE UP WITH ALUMINIUM NOTCHES SUPPORTS.

MAX DISTANCE FROM END OF ALUMINIUM TUBE WITHOUT NOTCHES TO CORNER ZINTRA SUPPORT CENTRE IS 22.5mm [0.9"]

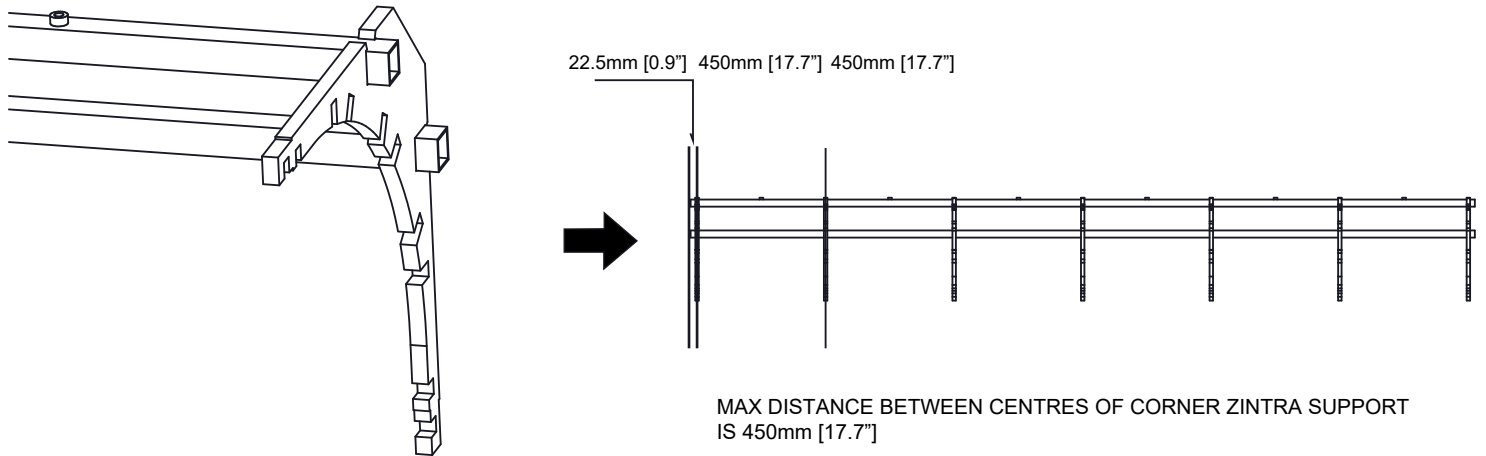

STEP 5

FOLD ZINTRA STICKS (28) FOR WIDE OR (55) FOR NARROW

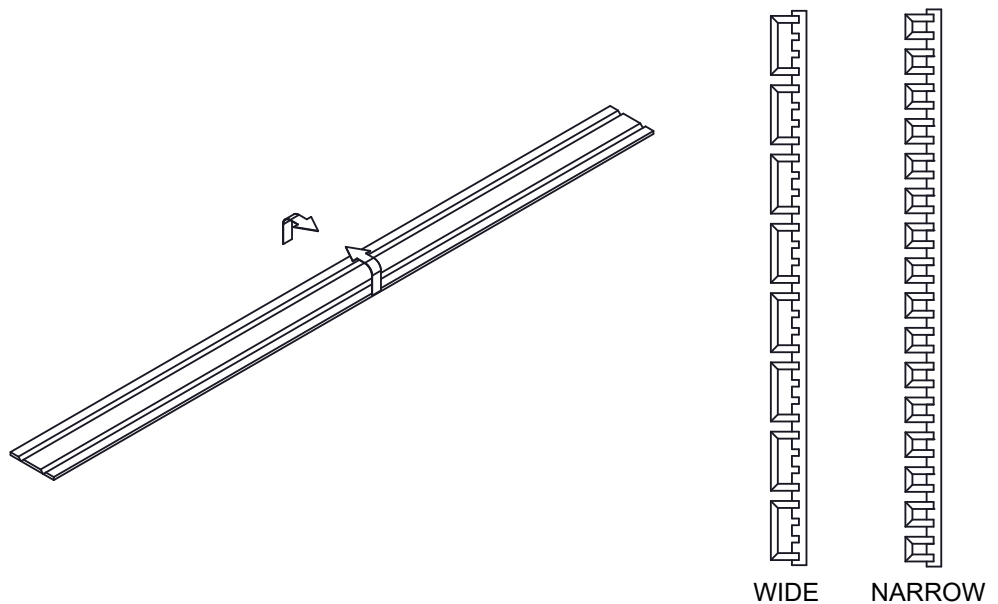

STEP 6

INSERT ZINTRA STICKS INTO TUBE NOTCHES
AS SHOWN

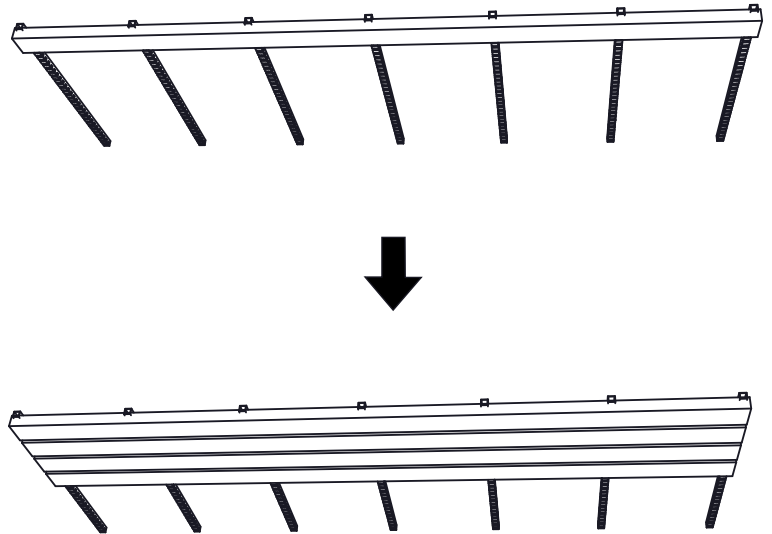
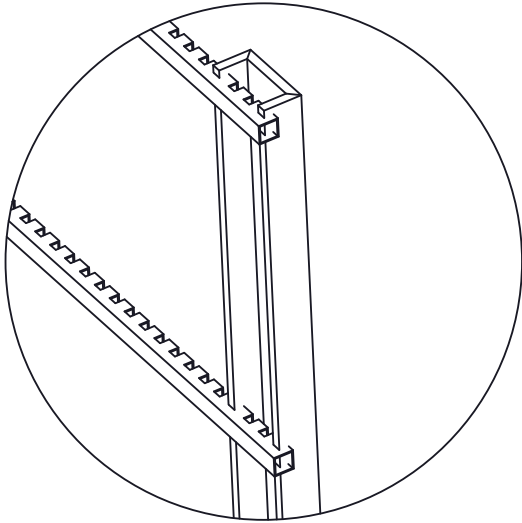

INSERT ZINTRA STICKS INTO CORNER ZINTRA SUPPORT
AS SHOWN

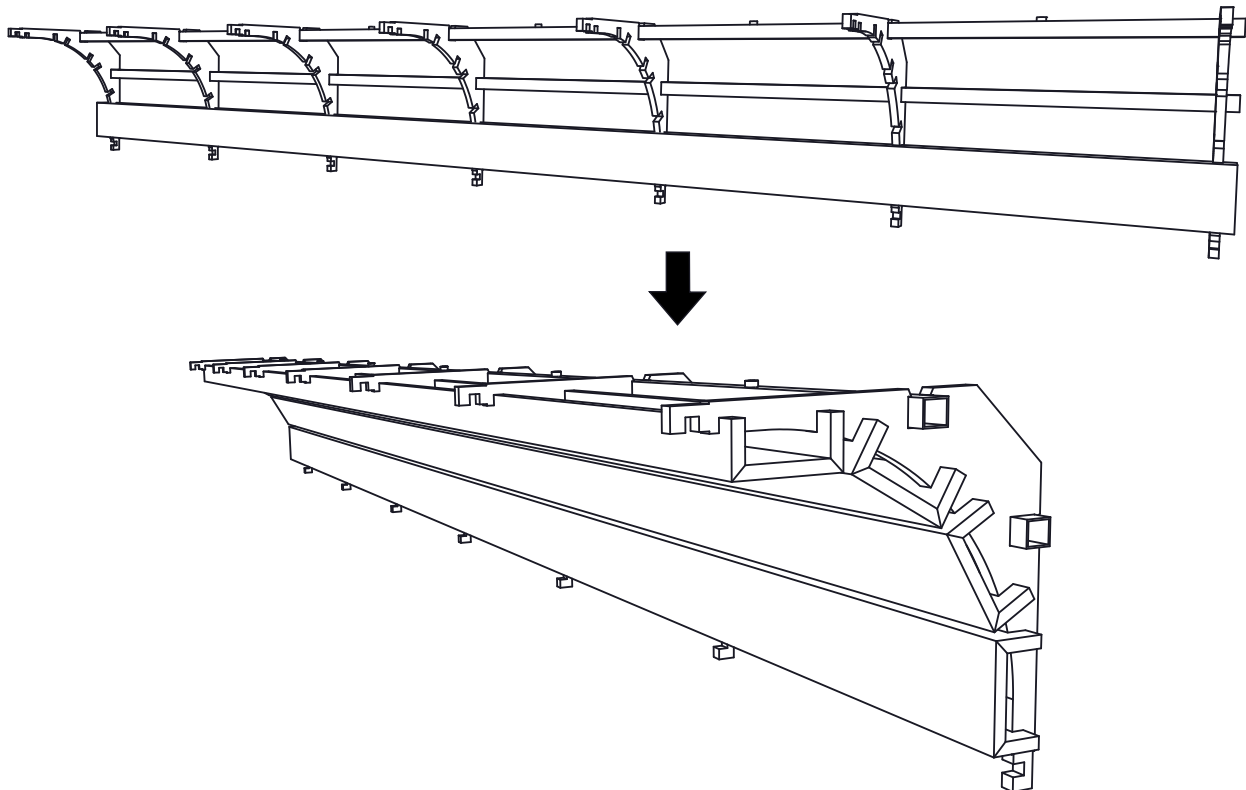

FINISHED INSTALL

